

## Circular Blades

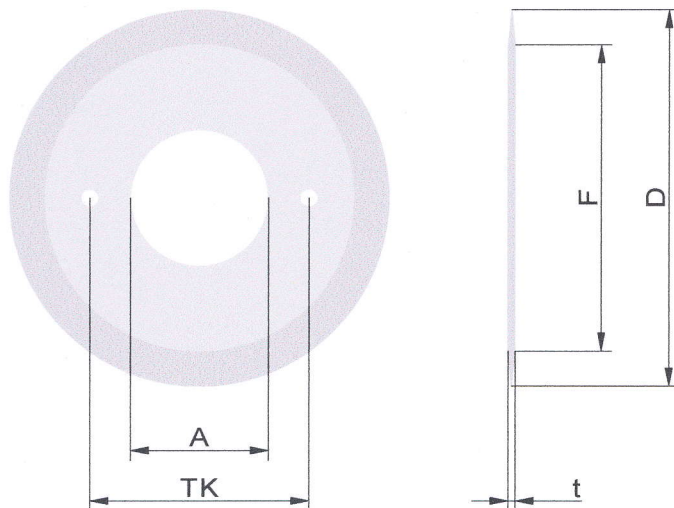

For manufacturing circular blades with straight or serrated edge we need the following information:



For generate a production drawing

Diameter	D	
Thickness	t	

		Shape	Size
Fixture	A		

		single bevel	double bevel	
Length of bevel	F			straight
		Pitch	Circle	Teeth
Holes	B			Hollows
Reference circle	TK			Slots

		1.2379	1.3343	1.4034	1.4112
Material					

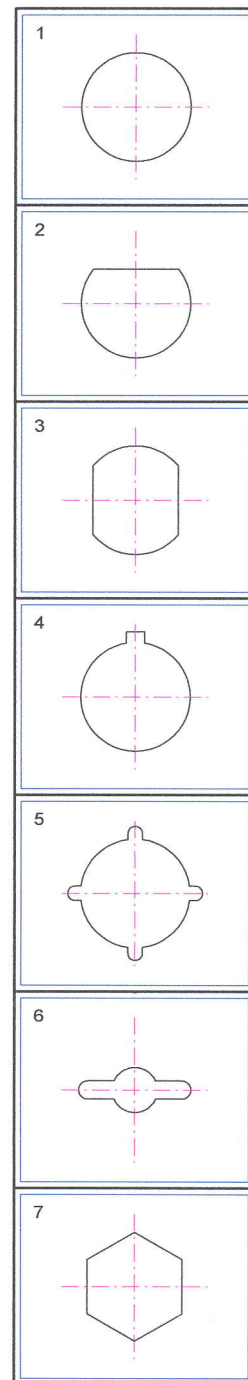

A selection of our tothing varieties



We might as well :  
 Bowl chopper blades/Chopper blades/  
 Skinner blades/Blades for frozen goods/  
 Circular slicer blades/Circular blades/Injector needles/  
 Slaughterhouse blades/  
 Punchen/Packaging blades/  
 Customized blades

Astor Schneidwerkzeuge GmbH  
 Lebbiner Straße 18  
 D-15859 Storkow  
 Tel. +49 33 678 649-0  
 Fax +48 33 678 649-22  
 info@astorblades.de  
 www.astorblades.de